

NOTE:  
ALL BOLLARDS ARE TO BE MADE WITH 304  
STAINLESS STEEL UNLESS OTHERWISE NOTED

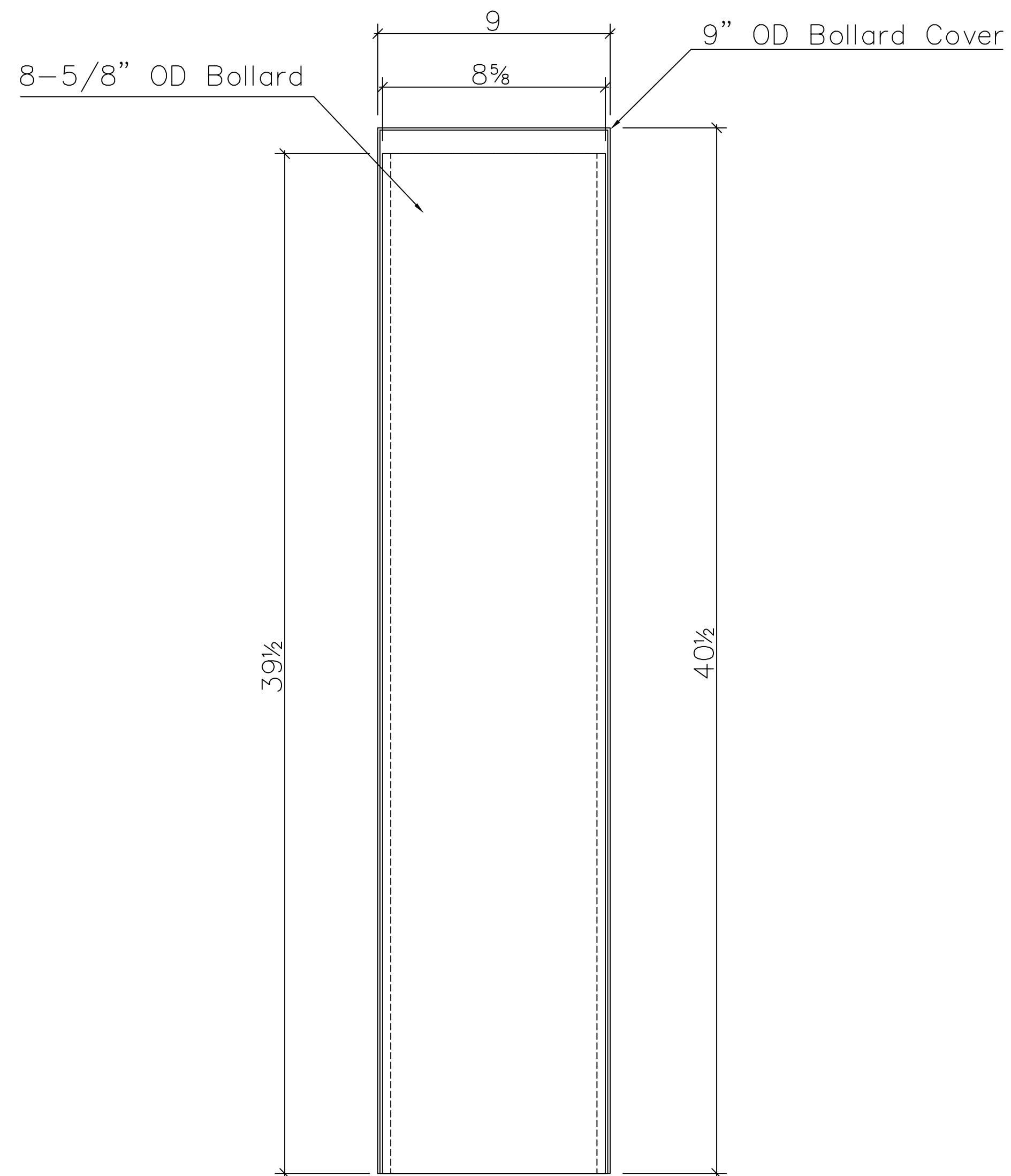

**Stainless Steel Bollard Cover**  
Product # SBC-1909-FL

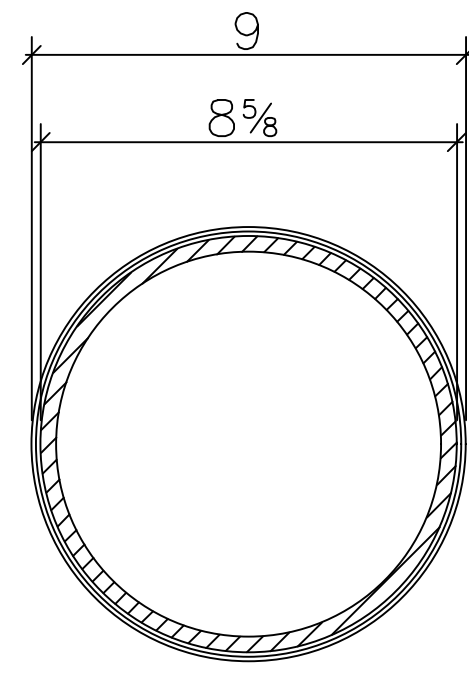

**Sloan Metal Solutions**  
6828 W. Melrose St.  
Boise, ID 83709  
Phone- 1.208.344.8379  
Fax- 1.208.344.8399  
www.SloanCompanies.com

Bollard Selections

Sloan Security Group

6828 W. Melrose St  
Boise, ID 83709

Rev.	Description	Date

Drawn By: ZD

Checked By:

Approved By:

Date: 5/24/24

Drawing Title:

Sheet Number: SBC-1909-FL

Job Number: 00000

APPROVAL OF SHOP DRAWINGS: shop drawings are prepared based on our interpretation of the design drawings. Incorrect, missing, or ambiguous information was detailed by scaling, calculating, or using our best judgement, and clouded for verification. If verification is not noted otherwise, it will be assumed correct as shown. Architect, engineer, construction management, and contractor shall review complete shop drawings for accuracy pertaining to the design intent and actual conditions for the project. After the approvals have been verified by the architect, engineer, construction management, or contractor, shop drawings for fabrication will be issued. The fabricator and detailer will not be held accountable for any design changes beyond that point.